

8 7 6 5 4 3 1

THIS DOCUMENT CONTAINS INFORMATION PROPRIETARY TO THE DONALDSON COMPANY, INC. MINNEAPOLIS, MINNESOTA. ALL RIGHTS TO MANUFACTURE, COPY, REPRODUCE, OR DISPOSE OF THIS DRAWING, OR ITS CONTENTS ARE RESERVED UNLESS SPECIFIED IN WRITING BY DONALDSON COMPANY, INC.

DWG NO.	REV	ZONE	REVISION DESCRIPTION	APPROVAL/DATE
	1		7.25 WAS 3.78 84.22 WAS 84.21 4.31 WAS 4.17 31.24 WAS 31.23 62.47 WAS 62.46 6696 WAS 66.84 STANDARD FINISH WAS STANDART 2004A6198	KS APR 28, 2004

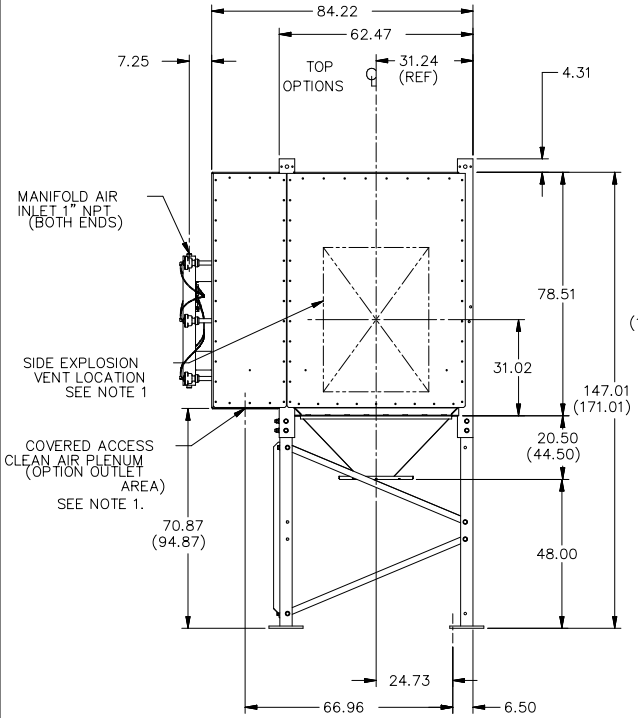

SIDE VIEW

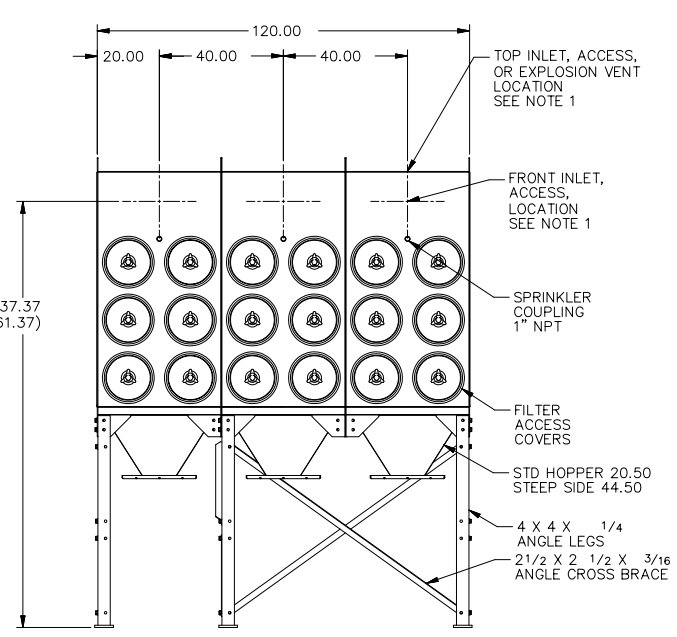

FRONT VIEW

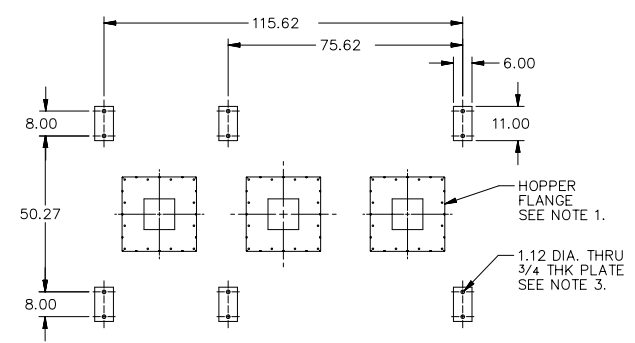

ANCHOR BOLT PLAN

TORIT DOWNFLO

SPECIFICATIONS FOR DFT 3-36

- REMOTE MOUNTED TIMER _____ 120 VAC 50-60 HZ
- NO. OF FILTERS _____ 36 (ULTRA-WEB)
- FILTER DIMENSIONS _____ 13.84 DIA X 26 LG.
- ACTUAL FILTER AREA _____ 9144 SQ. FT.
- SEISMIC RATING _____ ZONE 4
- WIND LOAD RATING _____ 100 MPH
- NO. OF VALVES _____ 18
- COMPRESSED AIR REQUIRED _____ 20 SCFM @ 90-100 PSIG
- HOUSING RATING _____ -20" WG
- OPERATING TEMP. _____ 150 ° F MAX.
- STANDARD FINISH _____ BLUE
- APPROX WT _____ 6100 LBS.

EXPLOSION VENT (OPTIONAL)

- USE ON NEGATIVE PRESSURE APPLICATIONS ONLY
- OPEN AREA PER VENT _____ 8.51 SQ.FT.
- MATERIAL _____ PTFE MEMBRANE
- NOMINAL BURST PRESSURE _____ 1.5 PSIG @ 100 ° F

NOTES:

1. SEE DFT-AD33109-01 FOR INLET, OUTLET, AND EXPLOSION VENT DETAILS.
2. SEE DFT-AD33110-01 FOR STANDARD ACCESSORIES.
3. USE HILTI 1.00 DIA HVA ADHESIVE ANCHOR BOLT SYSTEM WITH A MIN. 8.25 EMBEDMENT IN 3 KSI CONCRETE.
4. REQUIRES OIL FREE AND DRY COMPRESSED AIR.
5. DIMENSIONS IN () PERTAIN TO STEEP SIDED HOPPER.
6. DO NOT INSTALL OR OPERATE THIS EQUIPMENT UNTIL HAVING READ AND UNDERSTOOD THE INSTRUCTIONS AND WARNINGS IN THE INSTALLATION AND OPERATION MANUAL. FOR A REPLACEMENT MANUAL CONTACT DONALDSON COMPANY, INC. (800) 365-1331.

THIS PRINT IS NOT CERTIFIED FOR CONSTRUCTION PURPOSES THIS DOCUMENT IS SUBJECT TO CHANGE WITHOUT NOTICE

MATERIAL	RELEASE NO. 2003A7018 DATE JUN 2003 EXP DATE DWN J. SEVERSON	TITLE DFT 3-36 CABINET W/ HOPPER AND LEGS	
REFERENCE	DATE JUN 4 2003 CHK J. BERKHOEL	NUMBER DFT AD3311603	
PREVIOUS DRAWING NO.	DATE JUN 2003 APVD J. BERKHOEL	SCALE NONE SHEET 1 OF 1	REVISION 1
DO NOT SCALE	TOLERANCES UNLESS OTHERWISE SPECIFIED 2 PL # 3 PL # ANGLES # *	SECTIONAL SIZE DESIGN CONTROL A004 DWG LOCATION AT01	OUTLINE SIZE COPYRIGHT DONALDSON COMPANY, INC.