

**Affordable Automation  
for Welding, Cutting and  
Semi-Automatic Processes**

# Heavy Duty Tool Positioning System

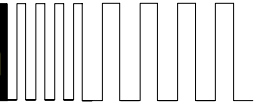

The **BUG-5275 H.D. WELDING GROUP** is designed to carry a welding gun along a smooth flat surface. It will mount on any standard BUG-O carriage. It consists of the following items:

**BUG-5275 H.D. Welding Group**

<b>A</b>	<b>BGV-1165</b>	Clamp Block
<b>B</b>	<b>BUG-2708</b>	Clamp
<b>C</b>	<b>BUG-3320-8</b>	H.D. Tube Rack 8" (203 mm)
<b>D</b>	<b>BUG-3320-15</b>	H.D. Tube Rack 15" (381 mm)
<b>E</b>	<b>BUG-5186</b>	Right Angle Clamp
<b>F</b>	<b>BUG-5188</b>	Torch Holder Assembly
<b>G</b>	<b>CON-1020</b>	Swivel Clamp Assembly

The **BUG-5285 H.D. CUTTING GROUP** is designed to carry a cutting torch along a smooth flat surface. It will mount on any standard BUG-O carriage. It consists of the following items:

**BUG-5285 H.D. Cutting Group**

<b>A</b>	<b>BGV-1165</b>	Clamp Block
<b>B</b>	<b>BUG-3320-15</b>	H.D. Tube Rack 15" (381 mm)
<b>C</b>	<b>BUG-5182</b>	Right Angle Clamp
<b>D</b>	<b>BUG-5188</b>	Torch Holder Assembly

The **HEAVY DUTY RACK SYSTEM** is a series of components which are designed to hold welding guns, cutting torches and other process tools. The system consists of tubes, blocks and clamps which are very rigid and compact. They are easy to use and can be mixed and matched in many different ways.

PATENTS WORLDWIDE



**BUG-O SYSTEMS**  
A DIVISION OF WELD TOOLING CORPORATION





3001 WEST CARSON STREET PITTSBURGH, PENNSYLVANIA USA 15204-1899  
PHONE: 1-800-245-3186 <http://www.bugo.com> TELEFAX: 1-412-331-0383

Distributed by Astro Alloys Inc. Houston, Texas 1-877-937-3838

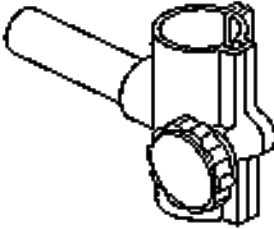
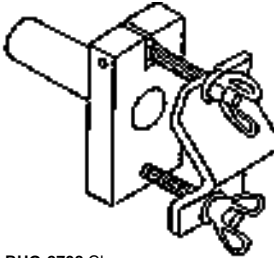
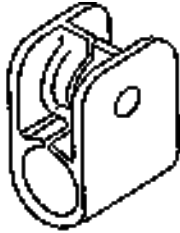

# Heavy Duty Tool Positioning System Accessories

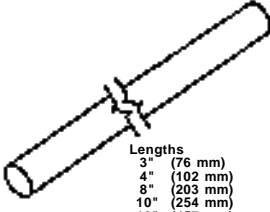
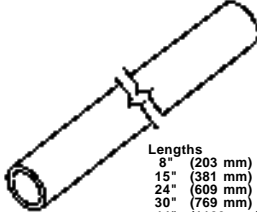
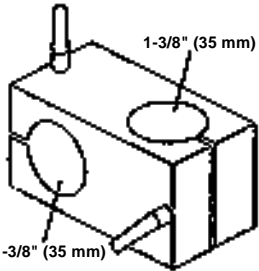
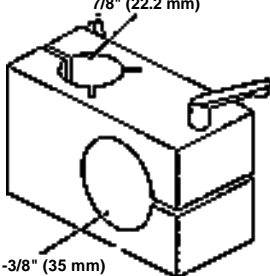
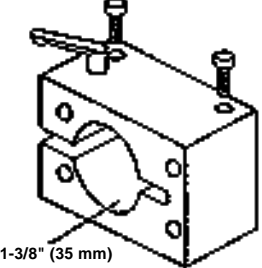
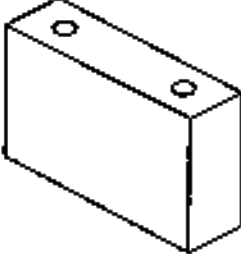
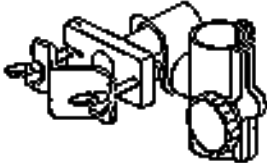
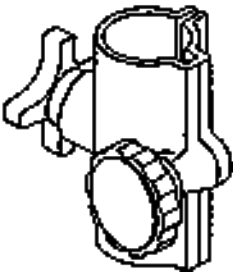
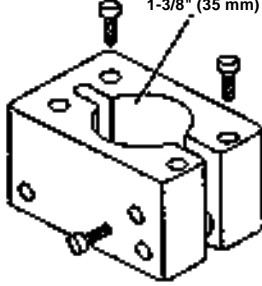
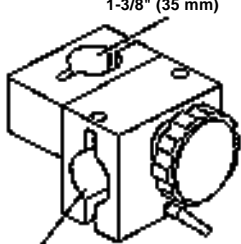
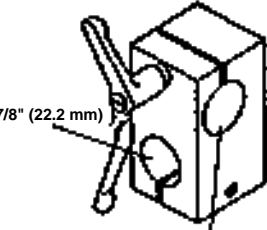
 <p><b>MUG-1515 Collar</b> 7/8" (22.2 mm)</p>	 <p><b>BUG-5188 Torchholder Assembly</b> w/7/8" (22.2 mm) Rod</p>	 <p><b>BUG-2708 Clamp</b> w/7/8" (22.2 mm) Rod</p>	 <p><b>PAN-1033 Rod Clamp</b> [7/8" (22.2 mm) Rod]</p>
 <p><b>CON-1020 Swivel Clamp Assembly</b> [for 7/8" (22.2 mm) rod]</p>	 <p><b>BUG-9180_ 7/8" (22.2 mm) Rod</b> (Specify Length) Additional lengths available.</p> <p>Lengths 3" (76 mm) 4" (102 mm) 8" (203 mm) 10" (254 mm) 18" (457 mm)</p>	 <p><b>BUG-3310 1-3/8" (35 mm) H.D. Tube w/o rack.</b> (Specify Length) Additional lengths available.</p> <p>Lengths 8" (203 mm) 15" (381 mm) 24" (609 mm) 30" (769 mm) 44" (1120 mm)</p>	 <p><b>BUG-5186 Right Angle Clamp</b></p>
 <p><b>BUG-5182 Right Angle Clamp</b></p>	 <p><b>BUG-5184 Tube Clamp Assembly</b></p>	 <p><b>PAN-1164 Spacer Block</b> (used w/limit switch)</p>	 <p><b>BUG-5245 Welding Gun Mounting Assembly</b></p>
 <p><b>BUG-2915 Torchholder</b></p>	 <p><b>BUG-5189 Clamp Block Assembly</b></p>	 <p><b>BUG-5280 Tube Mounting Rackholder</b></p>	 <p><b>BUG-5462 Right Angle Clamp Assembly</b> [for 7/8" (22.2 mm) Rods]</p>

## BUG-3320\_ H.D. Tube Rack (Specify Length)

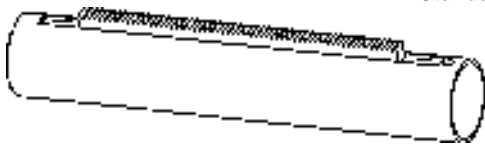

**Standard Lengths Available**  
(Specify Length)  
8" (203 mm)  
12" (305 mm)  
15" (381 mm)  
24" (609 mm)  
30" (760 mm)  
44" (1120 mm)

At the heart of the Heavy Duty System is the **BUG-3320\_ H.D. Tube Rack**. This rack consists of a 1-3/8" (35 mm) diameter steel tube that has a steel 32 pitch rack keyed into a machined groove that runs along its side. Choose the length that best suits your application.

The **BGV-1165 Clamp Block** is made from extruded aluminum with a steel pinion that allows for manually operated positioning of the BUG-3320\_ Heavy Duty Tube Rack. The clamp block also features a ratcheting lock-down lever for quick, easy tightening of the tube rack. It can be bolted to a fixture, or any BUG-O SYSTEMS carriage.

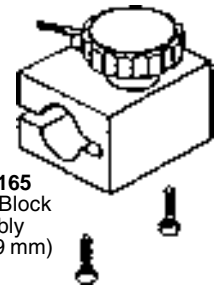

**BGV-1165 Clamp Block Assembly**  
3.5" (89 mm)